



ASSOCIATION OF
INTERIOR SPECIALISTS

Uniclass L387:JK40	EPIC C471
CI/SfB (35)	X (Ajv)

Site guide

Suspended ceilings



Serving the interiors sector www.ais-interiors.org.uk

AIS Site Guide for Suspended Ceilings



Contents:

Introduction	2
Association of Interior Specialists	2
Objectives; Membership and code of conduct.	
Types of Suspended Ceilings	4
Exposed or Lay-in grid; Concealed grid; Semi-concealed grid; Concealed grid for metal clip-in tiles; Metal strip; Open cell ceilings; Bespoke metal ceilings; Metal furring systems; Grid; Perimeter trims; Hangers; Access to the ceiling void.	
Materials	11
Quality of materials; Delivery to site; Receiving, handling and storage.	
Installation	11
Planning with the suspended ceiling contractor; When to install the ceiling; Sequence of installation; Integration of services.	
Fire Protection	14
Structural fire protection; Cavity barriers.	
Services Needed by Ceiling Contractor	15
Scaffolding; Electrical power; Lighting; Debris.	
Health and Safety	15
The Health & Safety & Work Act; The Construction (Design and Management) Regulations 1994; Site safety rules; Work at height; Step-ladders, trestles and stagings; Ladders; Stilts; Scaffolding; Mobile elevating work platforms.	
Completion	21
Provision of operation and maintenance manual; Maintenance.	
Swimming Pools, Leisure Buildings, Aggressive Environments	22
Summary	22
Appendix 1	23
List of references; Association of Interior Specialists references.	

Site Guide for Suspended Ceilings

Introduction

There are very few commercial building projects, new-build or refurbishment, which do not have suspended ceilings as one of their key construction components.

Usually representing the largest uninterrupted surface, they make a major contribution to the overall appearance and ambience of the finished space.

As a platform for lighting fixtures, HVAC diffusers, sound systems and wireless antenna panels, suspended ceilings deliver functionality to the building owner.

Some systems can contribute to structural fire protection.

For the construction team they offer a rapidly installed, dry and relatively clean process.

However, for the completed ceiling to meet the legitimate expectations of the building owner, occupier, design professionals and construction team, the selection and installation process must be carefully considered and understood by all parties.

Suspended ceilings are a finishing trade and require installation by specialist contractors. The specialist contractor will provide the high levels of management, operative skills and resources, essential to deliver a high quality product. Their considerable experience on similar projects will be of significant assistance to the construction team.

Most of the contractor members of the **Association of Interior Specialists** supply and install suspended ceilings.

They have satisfied stringent conditions of entry and have agreed to maintain high standards by adherence to the most current standards and codes of practice, together with manufacturers' recommendations as applicable.

The **Association of Interior Specialists** recommends that its contractor members are used to install the suspended ceilings, and a categorised national list is available.

This *AIS Site Guide for Suspended Ceilings* is not intended as a definitive technical manual, but rather an aide-mémoire and guide that will benefit main contractors, site managers/supervisors, designers, engineers and others involved with the building process. Additionally, it will help the reader understand the requirements of the suspended ceiling contractor if he is to fully function as a full member of the project team.

Association of Interior Specialists

A single source serving the interior fit-out industry, the **Association of Interior Specialists** represents companies involved in the manufacture, supply and installation of all aspects of interior fit-outs and refurbishment including suspended ceilings, partitioning, operable walls, drylining, platform floors, and office furniture and fittings. Our members operate in retail and commercial offices, the public sector, banks and building societies, hotels and leisure, airports, hospitals, and so on.

AIS membership is not automatic and applicants are subject to strict vetting procedures. In the case of contractors, this includes inspection of recent contracts to assess workmanship standards. On

being accepted into membership of the Association, members agree to abide by its code of conduct and conditions of membership.

Objectives

The main objectives of the Association are to:

- Raise, maintain and ensure continuity of standards.
- Be a source of quality membership.
- Provide a single voice and industry leadership for the interiors sector.
- Encourage and promote the use of members' products and services.
- Provide benefits to and represent the interests of its members.

In support of its objectives, the AIS encourages the application and use of interior systems; the development of suitable materials and systems; the use of correct installation practices; care in the selection and use of materials and systems; the use of agreed standard contract documents and contractual procedures. It is also concerned with the promotion of closer working relationships with the specifier and related specialist trades.

To achieve its overall objective of providing clients with the quality installations to which they aspire, the AIS requires the standards, materials, service and workmanship of its members to be of a very high order.

Membership and code of conduct

Membership of the Association is not automatic and applicants are subject to stringent vetting procedures. On being accepted into the Association, all members agree to abide by its code of conduct and conditions of membership.

The AIS code of conduct requires members:

- To conduct their business in a manner that will reflect credit on the Association and themselves.
- To adopt and commit to the principles and practices laid down by the Association.
- To act with the utmost integrity towards others, be they members or non-members, and at all times exercise high standards of business practice and workmanship.
- At all times not knowingly to mislead clients, architects or other employing bodies by fact or implication as to the performance of their products or systems.
- To ensure that they are, and remain, conversant with and adhere to the relevant current British Standards (and, where appropriate, international and European Standards) and other relevant technical Standards, Regulations and practices.
- In so far as they are able, to ensure that their products or systems are tested and/or comply with the recognised Standards specified by the client or statutory authority.

The Board and committee members bind themselves to treat in complete confidence private information concerning members of the Association, and information which is considered likely to bring AIS members into disrepute will be brought to the attention of the member(s) concerned before further action is taken.

Types of Suspended Ceilings

A wide range of suspended ceilings are available and they are being constantly developed and expanded to meet changes in regulations, standards and building design requirements.

The most common types of suspended ceilings can be summarised as follows.

Exposed or Lay-in grid

A system where the grid is visible and into which panels are laid. The grid is finished in colours to harmonise or contrast with the panels.

Panels are manufactured from a variety of materials including mineral/rock fibre, glass fibre, plasterboard, calcium silicate, glass reinforced gypsum, perlite, wood, steel and aluminium.

The system is rapid to install and can provide a high degree of access to the ceiling void. (Although with a suspended ceiling designed and installed to provide structural fire protection, the tiles would generally be clipped into position, which would prevent overall access to the ceiling void.)

Panels are available in a variety of sizes to suit the modular features of the grid system. The more common being 1200 x 600, 600 x 600 and 500 x 500mm.

Grid systems are, generally, an inverted 'T' design, with a table (exposed face) width of 15 or 24mm. They are rolled from galvanised steel strip with a finished facing of painted steel or aluminium. Grid systems may also have an exposed face that is rolled to a profile or have a profiled aluminium section applied.

Extruded aluminium exposed grid systems are also available.

The various components clip together to form square or rectangular modules to receive infill panels.

Panels have, most commonly, square or simple rebated edges, but some propriety products may have other edge details. A considerable number of face patterns and colours are available.

Many panels are designed for wide usage and have good general performance. Panels are also available with enhanced features, offering increased sound absorption, sound attenuation, heat insulation, resistance to humidity, etc.

Exposed grid suspended ceiling systems can contribute to passive fire protection – see later section.

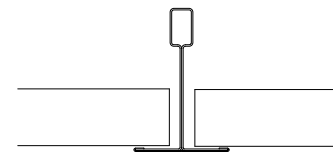

24mm grid & square edge panel

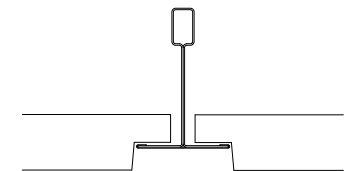

24mm grid & rebated edge panel

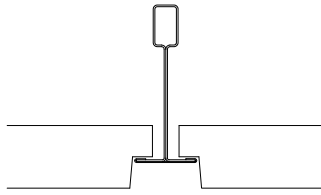

15mm grid & rebated edge panel
(square edge panels should not be used with 15mm grid)

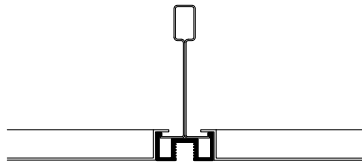

15mm profiled grid & steel panel
(square edge panels should not be used with 15mm grid)

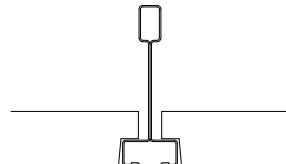

15mm profiled grid & rebated edge panel
(square edge panels should not be used with 15mm grid)

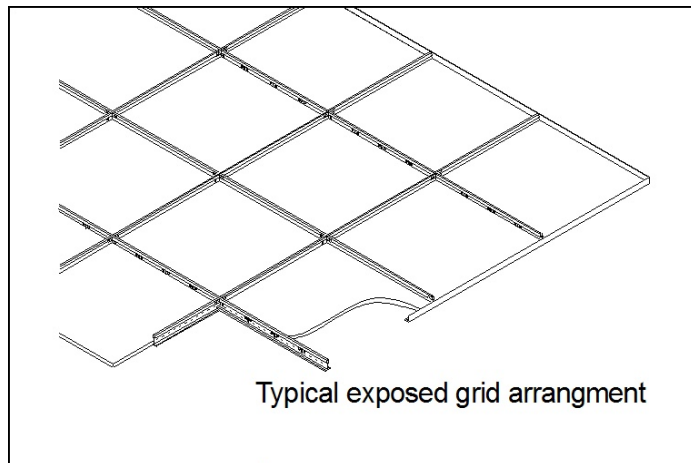

Typical exposed grid arrangement

Concealed grid (for tiles other than steel/aluminium)

A system where, after the tiles are installed, the grid is not visible. The system most commonly comprises galvanised steel 'Z' sections fixed with clips to a primary network of galvanised channel sections. Systems using inverted 'T' sections (similar to those described under 'Exposed or lay-in grid') may also be appropriate for specific manufacturer's tiles.

Tiles are manufactured from a variety of material, including mineral/rock wool, glass fibre, perlite cast plaster and wood. Edges may be kerfed (slotted), back-cut or tongued & grooved to receive the 'Z' or 'T' section. The butting edges of the tiles may be square or bevelled to create a 'V' joint feature.

Common sizes of tiles are 300 x 300 and 600 x 600.

Concealed grid systems require an extremely high standard of workmanship to achieve a satisfactory installation.

Typical concealed grid

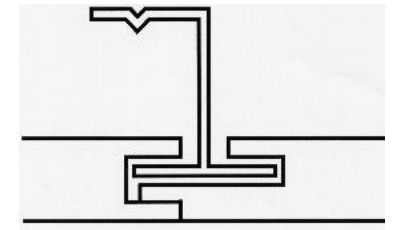
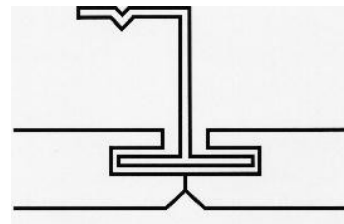

Semi-concealed grid

A system where the grid is visible in one direction only. The exposed grid sections would generally be a 24mm 'T', as described under 'Exposed or lay-in grid'. The concealed components may be similar 'T' section, 'Z' section (usually 32mm deep) or a special deep 'cranked Z'.

As the grid components do not interlock spacer bars must be used to prevent the exposed tee sections 'spreading' allowing panels to fall.

This system is designed to support 'planks' – tiles that are 300mm wide and 1200, 1500, 1800 and up to 2500mm long. The exposed sections support the shorter edges.

Planks are manufactured from a variety of material, including mineral/rock wool, glass fibre, wood, steel and aluminium. The short edges are square cut and the long edges may be kerfed (slotted), back-cut or tongued and grooved to receive the 'Z' or 'T' section. Planks manufactured from steel or aluminium will, generally, not require the longitudinal (concealed) components.

The butting edges of the planks are usually bevelled to create a 'V' joint feature, but may be square – metal versions may have a separating foam gasket.

Semi-concealed systems can offer access to the void above the ceiling, but, if required on a regular basis, care should be exercised in the selection of plank material.

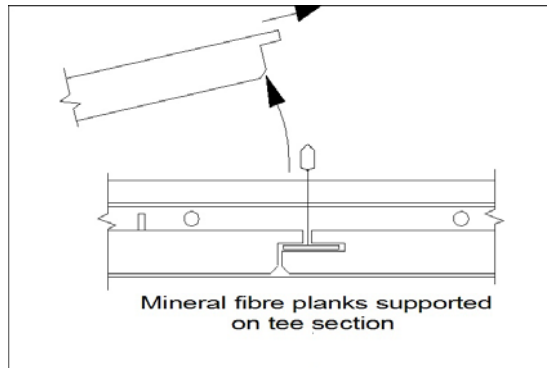

Concealed grid for metal clip-in tiles

A system where the grid is not visible specifically designed for metal tiles. The system comprises a 'spring T' or 'A' bar (also known as 'Omega') that supports the tiles. This section is fixed to and below a primary grid, usually a galvanised channel section. (Direct suspension of the tile carrying component is possible, but not common.)

Tiles are manufactured from steel and aluminium with square and/or bevelled edges. The tiles are usually painted and the face may be plain or perforated. The holes, of specified diameter, can be in straight rows or on a diagonal pitch.

Various materials can be placed in the back of the tiles to provide or enhance sound absorption, sound attenuation and passive fire protection. The infill material will, typically, be of mineral wool enclosed in an aluminium foil envelope. Mineral fibre board is also used.

The tiles have, on their upturned edges, an arrangement of 'pips' that locate into the tile supporting section. A method of controlling the level of the tile face when installed (referred to as the 'stop') will also be incorporated.

Tiles are available in various standard lengths and widths; most commonly, 600 x 600mm, 1200 x 600mm and 300 or 600mm wide by up to 1800mm long. Special sizes and shapes are also available. Tiles can be removed from the grid by a suitably instructed operative using the appropriate tools.

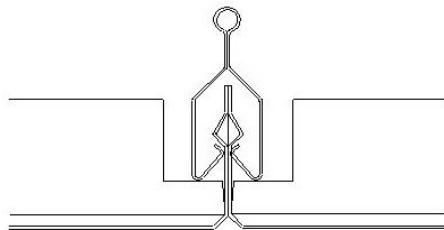

'A' bar with clip-in metal tile

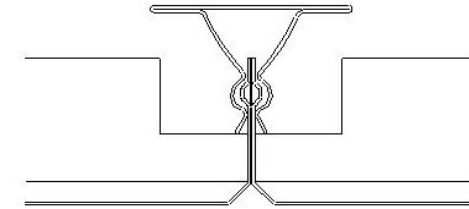

Spring 'T' with clip-in metal tile

Metal strip

A system of rolled narrow (300mm or less) panels fixed to the underside of 'carriers' that may be concealed or visible.

The carriers, manufactured in steel and aluminium, are punched at modular centres to receive the panels. (Carriers are unique to their manufacturer and designed for use with their panels – they are not interchangeable.)

The panels are available in steel and aluminium, in numerous colours, plain or perforated.

Perforated panels may have an infill material to enhance their acoustic performance.

The panels are usually made to order and are available in lengths limited only by their transportability, access to the installation point and site handling issues.

The design of panels is such as to form an 'open' or 'closed' ceiling.

'Open' strip ceilings may have an overlay 'blanket' of acoustic or other material, to obscure the view into the ceiling void.

Panels can be removed for access, but, if frequent access is required, specific detailing may be necessary.

Open cell ceilings

Open cell systems consist of panels of metal blade construction, mineral wool, mdf or glass reinforced gypsum (GRG).

Metal blade products can be supported directly, but some will require a supporting grid. Mineral fibre, mdf and GRG will require a grid system.

Generally the products are designed to create a 'non-modular' appearance, with the grid (where required) blending in with the panel.

Luminaires can be mounted above an open cell ceiling to create widely diffused illumination. Alternatively, spotlights and downlighters specifically designed for open cell ceilings are available.

Subject to the degree of 'open area' fire suppression systems can be positioned above this type of construction.

The opportunity to integrate air handling systems within and through the ceiling is also available.

Open cell ceilings may have an overlay 'blanket' of acoustic or other material, to obscure the view into the ceiling void and/enhance aspects of acoustic performance.

Bespoke metal ceilings

Suspended ceiling systems designed for specific projects. These ceilings are tailored to suit building layouts in a variety of modules sizes and can incorporate lighting, ventilation, heating and air cooling.

These ceilings, although they will follow the same basis principals of more common types, will need more detailed planning.

Metal furring systems

A galvanised grid system designed for the purpose with single or multi layer plasterboard screw fixed to the underside. Traditional systems comprise of primary channel supports to which the 'furring' bar is clipped or screwed. Support systems based on directly hung inverted 'T' sections are also in use.

The plasterboard is taped, filled and top coated or plaster skimmed to create a monolithic surface suitable for in-situ decoration.

Metal furring systems are particularly suitable for forming vertical changes of level, margin and other details. Extruded aluminium sections are available for smaller changes in level. Aluminium extruded sections are also available to detail the junction between plasterboard ceilings/perimeters and modular suspended ceilings

Entry to the ceiling void requires the construction or integration of site formed or proprietary access panels/doors.

Grid, perimeter trims, hangers and access to the ceiling void

Although each ceiling system has components specific to that type, there is a common logic to the construction requirements and many shared items.

Grid components

Ceiling grid sections are normally made from cold rolled steel strip and protected by galvanising, which will be suitable for the majority of projects. Harsh and/or corrosive atmospheres in, for example, swimming pools (see section on *Swimming Pools, Leisure Buildings, Aggressive Environments*) or external situations may require grids with more robust protective coatings.

Perimeter trim

Most systems will require a perimeter trim to conceal the cut edges of tiles, secure perimeter panels, provide minor support to some grid items and provide a neat junction detail with a wall or other constructional element.

Perimeter trim may be a simple 90° angle section of painted or capped rolled steel or extruded aluminium, or may be designed to create a 'shadow' gap between the ceiling and the wall.

Channel section trim and wedges are often required to hold the cut edges of metal tiles flat on the trim.

Adjacent lengths of rolled steel perimeter trim are simply butted together, although extruded aluminium items may have provision for a splice.

Rolled steel trim at internal and external corners can be site cut to form a 'true' mitre, an overlap or dummy mitre, square overlap or butt cut. Propriety corner covers are available but rely on the fixing surface to be accurately formed.

Thicker extruded aluminium trims will need to be site cut to 'true' mitres.

Hangers

Most suspended ceilings will, by definition, be hung at a distance below the structural soffit.

Hangers may be pre-straightened wire, angle section, threaded rod, flat strap or proprietary adjustable devices. The spacing of hangers is critical to the appearance and integrity of the ceiling and varies with the type of ceiling and the loads that are to be carried. When planning the type and spacing of hangers, additional loads imposed by lighting fixtures etc must be considered. If hanger positions are obstructed by void mounted equipment or limited by the design of the structure, bridging may be necessary to maintain acceptable spacing.

Attachment of hangers to the structural soffit is of fundamental importance. Extreme care must be exercised in the selection of the fixing device. Consideration must be given to the soffit material, the load to be carried and a suitable safety factor multiple (usually 3 or more). Site testing of the chosen fixing would be reassuring and responsible.

The consequence of a failure of the soffit fixing device is potentially catastrophic and life threatening.

The attachment of the hanger to the ceiling grid deserves equal consideration.

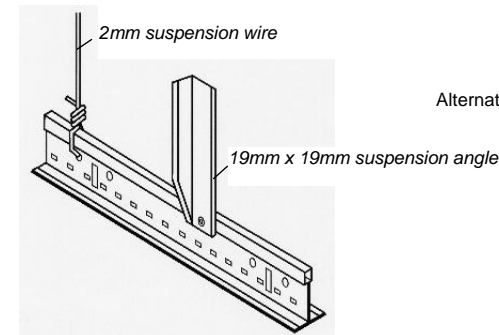

Alternative suspension methods

Access to the ceiling void

For suspended ceiling systems that offer no or limited access to the void, purpose made or proprietary solutions are available.

Where access is needed infrequently it may be possible to form a removable panel by modifying the ceiling to allow an individual tile or panel to be taken down and subsequently replaced.

For frequent entry proprietary access panels may be appropriate. Many designs feature downward opening doors that can be infilled with matching ceiling panels.

The durability of the ceiling and the chosen access solution will be reliant on maintenance personnel receiving detailed instruction in their use.

Materials

Quality of materials

The project specification will usually name products from particular manufacturers. The materials will have been selected by the designer for specific performance characteristics and appearance. If consideration is given to installing products of alternative manufacture, great care should be exercised to ensure they fully match the original specification. Similar appearance is no guarantee of compliance.

Many of the major manufacturers are members of the **Association of Interior Specialists**.

Delivery to site

The majority of materials are delivered to site by manufacturer's authorised distributors. These specialists have the logistic resources and experience to ensure timely delivery and safe handling.

Most of the major distributors in the UK are members of the **Association of Interior Specialists**.

Receiving, handling and storage of materials

Ideally, an on-site delivery point should be designated that will allow suitable access for delivery vehicles. The area should allow for the safe and considerate handling appropriate to finishing trade material.

Most material can be palletised and off-loading by fork-lift truck will generally minimise damage.

The careful checking of delivery notes against actual consignments will help safeguard against later delays due to shortage or wrongly delivered material.

Movement of material from the delivery point to the installation area usually represents the greatest opportunity for damage, particularly if being achieved manually.

- All ceiling materials should be handled with care – applies to both grid and panels.
- Cartons should not be dropped, rolled or slid.
- Cartons should be stacked the right way up on a dry, clean and flat base.
- Materials should be adequately protected from inclement weather.
- Materials should be protected from impact damage.
- Stacked materials should not be used as ad-hoc scaffold or mess tables.
- Observe the manufacturer's recommendations for stacking and storage.
- Operatives should wear protective clothing, which may include gloves, and use proper handling equipment. (See also *Health and Safety* section.)

The concentrated stacking of large quantities of materials may create structural loading issues. The floor loading design of the building or platform should be carefully considered and, if necessary, the material evenly distributed.

Installation

Planning with the suspended ceiling contractor

The installation of suspended ceilings is a key element in the construction programme. A finishing trade that also provides a platform for many of the services trades, its progress can be pivotal to the

completion of a building. Installation is relatively fast and early planning with the ceiling contractor and interfacing trades is vital.

The main contractor and the suspended ceiling contractor will need to:

- Agree firm start and finishing dates at the time of entering into contract.
- Develop a detailed programme of work, which may include:
 - Dates for the receipt of further design information.
 - Dates for production and approval of working drawings.
 - Dates for delivery of materials, and scheduling of phased deliveries.
- Issue/receive the latest issue of drawings relevant to his work, which would include reflected ceiling plans and the layout of lighting and other services outlets in the ceiling. This information should be integrated on one drawing and related to setting out points to be used by all trades.
- Agree the type of soffit fixing to be used.
- Consider the interface of the suspended ceiling with perimeter details - window heads, blind boxes, upstands, plasterboard margins etc.
- Consider interaction and potential conflicts with structural and services components. These usually include:
 - Dimensional co-ordination of recessed luminaires and other terminal equipment with the tile/panel module.
 - Additional support for luminaires, air distribution outlets, etc. When ceiling tiles/panels are to be partially supported by luminaires or air terminal devices, ensure that flanges are adequate and correctly dimensioned.
 - Lateral stability of ceiling grid when interrupted by electrical trunking, continuous rows of luminaires or other ceiling level equipment.
 - Obstruction of ceiling hangers by ductwork, cable trays etc.
 - Insufficient vertical space where ductwork, recessed luminaires and/or ceiling suspension components overlap.
 - Restricted headroom for upward opening access panels.
 - Sprinkler heads clashing with main support sections of the ceiling system.
 - Location of access panels for services.

When to install the suspended ceiling?

'The installation of suspended ceilings is a key element in the construction programme. A finishing trade that also provides a platform with many of the services trades, its progress can be pivotal to the completion of a building.'

Before the commencement of the ceiling installation some important factors should be considered. These will include:

- Suspended ceilings cannot effectively be protected once installed. Other trades working through or under ceilings pose a high degree of damage risk.
- Ductwork and pipe work should be installed, tested and lagged. Once installation of the ceiling has commenced access for bulky equipment and operatives becomes problematic.
- Cable trays should be installed and loaded. Pulling cables though completed or partially completed ceilings can cause damage to both the ceiling and the cables.
- The building envelope should be weather tight. Suspended ceiling components are interior products and should not be exposed to inclement weather.
- The building should be substantially dried out and/or means of controlling humidity in place. High levels of humidity can have a detrimental effect on some ceiling products and the manufacturer's

recommendations should be followed. Heating may be necessary to prevent condensation forming overnight or during other periods when the building temperature drops. (Note: The use of gas heaters can create vast quantities of water vapour which will need ventilating or collecting.)

- The building should be relatively clean. Cleaning operations can create large volumes of dust which may adhere to the surface of the ceiling.
- Suspended ceiling of plasterboard on metal furring can be more tolerant of site conditions, although lack of casual access to the void will be more of an issue. Plasterboard can be affected by humidity and condensation.
- A two stage installation process can, with some suspended ceilings, be practical. The grid being installed without the panels, which are placed at a later stage. (The increased cost of such working should be dealt with at tender stage.) Between the two stages lighting fixtures, air terminal devices and other ceiling mounted items can be placed. Great care should be exercised by the 'other trades' as the incomplete ceiling can be susceptible to damage and/or misalignment. It may be necessary for the ceiling grid to be braced/reinforced to increase its resistance to being disturbed. Two stage installations can assist with issues of high humidity/condensation by the placing of the more vulnerable products to later in the building programme.

Sequence of installation

Most suspended ceilings are installed as a continuous operation, the operatives following one another in a practiced progression and not necessarily completing one task before starting the next. Most will follow a logic that will track the following operations:

- Setting out points and elevation benchmarks are identified and related to design/layout drawings.
- Design dimensions are checked against actual construction.
- The proposed ceiling module layout is checked for inconsistencies.
- Finished ceiling heights are established and related to installed services and the clearance required for the ceiling system. (A rotating visible light laser can be useful at this stage.) The relative height of the ceiling/perimeter interface can also be checked.
- Setting out of the ceiling with the use of string lines and/or lasers with particular emphasis to establishing 'square' reference lines.
- Installation of the perimeter detail.
- The position of fixings into the structural soffit is determined and installed. Hangers are attached to the soffit fixings. (Working platforms may need to be raised to reach structural soffits.)
- Hangers may be levelled at this stage, depending on the type of hanger and the ceiling fixer's preference.
- The ceiling grid is installed and panels placed, unless a two stage process has been agreed.
- Apertures for some ceiling mounted items such as downlights will be formed.

Integration of services

Where services items such as continuous slot diffusers and lighting provides support to the ceiling and effectively dictates the layout, consideration should be given to these being positioned by the specialist ceiling contractor. Spotlights, luminaires and other service fittings should not be supported directly onto the back of tiles or panels. A pattress or other suitable method must be used to ensure any load is transferred to the grid. The manufacturer's guidelines on such loads should be consulted and direct independent suspension used where exceeded.

All materials and components should be installed in accordance with the recommendations of the manufacturer or supplier.

Fire Protection

Structural fire protection

Comprehensive coverage of the contribution suspended ceilings can make to structural fire protection is too complex for this publication. An understanding of the actual regulations may be assisted by reference to publications by the leading manufacturers and discussion with your local building control officer. The following points should also be considered:

- If a suspended ceiling is intended to contribute to the structural fire protection of a building, the tendering ceiling contractors must be informed. Such ceilings may require specific materials and will need particular construction details.
- Work should be undertaken by contractors with experience of such installations, using operatives with full understanding of the fixing requirements.
- The ceiling installation must conform in every respect with the tested or assessed design. Full constructional details and a full copy of the relevant fire test report or assessment document must be available to the ceiling contractor and main contractor.
- Any proposed deviation from the tested system must be subjected to evaluation by a competent authority. Re-testing may be necessary.
- The existence of a suspended ceiling that is contributing to the structural fire protection of a building should be made known to the building owner, with instructions for its future maintenance and the preservation of its integrity.

Cavity barriers

Regulations call for the control of fire, smoke and gases in ceiling voids. Generally, the regulations limit the dimensions (length, width & volume) of ceiling voids and specify requirements for various types of barrier.

The provision and construction of cavity barriers should be thoroughly researched, but the following should be considered:

- Cavity barriers should be installed at the specified intervals. Building design/practical considerations may dictate placing barriers at closer centres than called for.
- Cavity barriers must satisfy the requirements of current Building Regulations.
- A satisfactory seal must be made where a barrier abuts the structure and the use of both rigid and flexible materials, in combination, may be necessary.
- Where services penetrate a barrier its effectiveness must be maintained by effective and approved sealing.
- The building regulations provide for the use of a suspended ceiling in lieu of cavity barriers. Such ceilings are rarely used and require particular considerations. This type of ceiling has special constructional details and is intended to protect an area below the ceiling from a fire in the void above. It must not be confused with the relatively more common ceiling discussed under *Structural fire protection* above.

Services Needed by Ceiling Contractor

Scaffolding

The responsibility for the provision of working platforms for the erection of suspended ceilings should be established at tender stage. Tendering ceiling contractors will, if required, include the equipment, the associated costs of erecting, moving and the relative production efficiencies of working from their chosen solution. If working platforms are to be provided by the main contractor as part of his 'attendance' the particular requirements of ceiling installation should be considered.

Scaffolding provided by the main contractor for general construction purposes is unlikely to be suitable for the needs of the suspended ceiling specialist. When installing grid and panels a fully boarded platform approximately 1800mm below the finished ceiling height is required to an area consistent with the progress of programme. Higher platform levels may be required to enable soffit fixings and hangers to be installed. If mobile scaffold towers are to be provided, their type and the quantity to be provided must be fully described in the tender documents.

Where mobile scaffold towers are to be used, a clear floor area will be needed to allow their safe and efficient use. Floor mounted services are a particular hazard and impedence.

Regulations governing the erection and use of working platforms will have a strong influence on what needs to be provided and its use.

Further reading on working at height, refer to the Health and Safety section, Work at height (page18).

Electrical power

A continuous and reliable source 110-volt power will be required near to the work locations for electric tools. The number of outlets should be commensurate with the number of operatives employed installing suspended ceilings.

Lighting

Temporary site lighting is vital for safety. High quality task lighting will be needed to ensure a high standard of workmanship. As a finishing trade the suspended ceiling will be viewed as part of a complete interior design with, usually, a high level of illumination. It would not therefore be unreasonable for the ceiling to be installed in similar conditions.

Debris

A volume of packaging material and off cuts will arise from the installation. Generally the ceiling contractor will take these to agreed points on each level for clearance by the main contractor.

Health and Safety

Construction sites have a poor record of safety and considerable legislation exists. Much is generalised, whilst some reflects particular risks such as working at height or the use of hazardous materials. Main contractors and specialist subcontractors will have developed their own health and safety regimes that take in current regulations. All members of the construction team have a duty of care to their site colleagues. Working to agreed programmes and to formalised method statements

can contribute to site safety. Identifying hazards and assessing potential risks should cover the working environment, the work to be done, the tools to be used and the materials to be installed.

The Health & Safety at Work Act

The Health & Safety at Work Act 1974 imposes a general duty on employers to ensure so far as is reasonably practicable the health, safety and welfare at work of all their employees. The Act also provides, without prejudice to the generality of their duties, a list of specific duties of employers in respect of their employees. Contractors should play their full part in overall safety on site by adhering to the specific provisions and by making their site personnel aware of the need to conform to site safety rules at all times. Full co-operation should be sought from all other parties to the contract as far as site operations are concerned.

The Health & Safety at Work Act 1974 also requires that materials and products are safe and without risk to health when properly used. However, when materials and products that are potentially harmful are used, it is imperative to adhere to the manufacturers' instructions and recommended safety precautions. The Control of Substances Hazardous to Health Regulations (COSHH) relate to these duties under the Health & Safety at Work Act and employers must meet their obligations in respect of this legislation.

The Construction (Design and Management) Regulations 1994 (amended 2000)

The CDM Regulations place duties on all those who contribute to health and safety on a construction project, including clients, designers, planning supervisors, principal contractors and contractors. They also require development of the Health and Safety Plans and creation of the Health and Safety File.

The CDM Regulations apply to most construction projects, although there are certain exclusions. In consequence, the contractor will be involved in projects that fall within scope, eg some new building contracts, and projects that fall outside, eg some refurbishment contracts. The CDM Regulations apply except where:

- The construction work will last less than 30 days and involves less than 5 people (other than for demolition).
- The construction work is for a domestic client.
- It involves the maintenance or removal of pipe or boiler insulation, or other parts of heating or water systems.
- The construction work is carried out inside offices, shops or similar premises and does not cause any interruption of the normal activities carried out on the premises, and where the construction works are not physically separated from those other activities.

The aims of the CDM Regulations include the following:

- To ensure that all parties consider the hazards and risks associated with the work or location in advance.
- To encourage project planning, ie the co-ordination of activities.
- To ensure that a written control document, the Health and Safety Plan, is developed.
- And, that future work and maintenance issues are considered.

If there is any doubt as to whether or not a fit-out contract falls within scope of these Regulations, the advice of the local Health & Safety Executive representative should be sought. For further information on The Construction (Design and Management) Regulations 1994 and Risk Assessment,

see AIS Fact File Information Sheets AIS 016 *The Construction (Design & Management) Regulations 1994 (CDM)*; 004 *Health and Safety Policy*; and 005 *Risk Assessments*. See also *Managing Construction for Health and Safety*, The Construction (Design and Management) Regulations 1994 Approved Code of Practice HSG 224 (an update on the earlier L54 issue).

The importance of compliance with these regulations cannot be overstated as the authorities are looking for a responsible approach to be taken by all those involved in any form of construction related activity.

Site safety rules

All employees should adhere to the following:

- Upon arrival on site they should report to the Project Manager, Site Agent or client contact and familiarise themselves with specific site safety and health regulations. They should also identify the nearest fire alarm point, fire exit, fire extinguisher and first aid box to their place of work.

They should also:

- Work in accordance with any agreed Safe System of Work or Method Statement.
- Acquaint themselves with the fire procedures for the site or building and observe the relevant rules.
- Obey all site instructions regarding the wearing of personal safety equipment such as hard hats, safety glasses, ear protection, footwear, etc.
- Know to whom all accidents are to be reported and the procedures to be followed.
- Know to whom all defects in plant and equipment must be reported.
- Keep all gangways, exits and work areas clean and tidy and ensure that fire exits and staircases are kept free from any materials or debris, especially in occupied premises.
- Maintain good housekeeping throughout all areas of work by never leaving floors wet, and lifting and clearing waste regularly. Be aware that other site personnel may not be familiar with the working practices involved, for example, in the installation of partitions and/or suspended ceilings.
- Provide adequate protection and signs for the safety of others when their activities create a hazard.
- Never run, especially when on scaffolding.
- Obtain assistance when heavy items require to be lifted. Always bend knees and lift with a straight back.
- Follow correct hygiene and first aid procedures in the event of minor injuries. (Injection against tetanus for site operatives is recommended.)
- Ensure that machine and hand tools are used correctly and that worn tools and equipment are replaced.
- Acquaint themselves with the safety rules regarding the use of special machines and, where appropriate, use guards; avoid wearing loose clothing near moving machinery, and not wear ties and rings when using power tools or similar equipment. (It is inadvisable to use special power tools if working alone on site.)
- Refrain from interfering with or adapting any equipment or service without proper advice or permission.
- Refrain from nailing objects to ladders and steps, do not remove guard or kick rails on towers or scaffolding.

- Obey site instructions concerning mobile plant and never ride on open hoists.
- Ensure electrical equipment is properly connected. Safe working practices require the use of 110-volt power supply. Where practicable, electrical plant when not in use should be isolated.
- Ensure all precautionary measures advised by the manufacturers are taken when lasers are to be used.
- Ensure that if hazardous materials are identified during the course of the work, the site Health & Safety Officer and the installer company is advised immediately.
- Wear safety glasses and gloves and other appropriate protection when handling glass, particularly annealed glass. Damaged glass should be broken into small pieces and placed into boxes or bins marked 'Danger - broken glass'; do not place into sacks or bags.

Work at height

In April 2005 the law regarding Work at Height changed. The most significant change was to make every employer responsible for considering whether there is any risk associated with fall from height – regardless of how far the fall might be.

There is no longer a 2m rule

Whether working at 1m or 10m from the ground you can be seriously hurt or worse if you fall.

Employers must consider the risks associated with tasks being performed and should apply the following considerations to each situation.

- Can the work be done without working at height?
- If not, can a safe platform be established?
- If not, can suitable access equipment be used?
- If not, can collective fall protection be used? (Nets, bean bags, air bags or crash decks)
- If not, can personal fall protection be used? (Fall restraint or fall arrest)

This general guidance should always be considered along with the specific information in the relevant sections in this Site Guide and the AIS Health and Safety Handbook.

These new regulations have not outlawed the use of steps and ladders but they do require serious consideration to be given as to whether they are the most appropriate access equipment.

Podium steps or small platforms may be more appropriate in some circumstances.

Step-ladders, trestles and stagings

The main hazards associated with step-ladders, trestles and stagings are:

- Unsuitable base, eg unlevelled, packing pieces, loose material etc.
- Unsafe use of equipment (on scaffold platforms, roof etc, where special precautions are not taken).
- Overloading.
- No edge protection on stagings.
- Use of equipment where a safer method should be provided.
- Overhanging of boards or staging at support ('Trap Ends').
- Using defective equipment.
- Excessive span of scaffold boards when used with trestles (eg boards must not exceed 1.2m where 38mm boards are used).
- All stagings where persons may fall and be injured must have guard-rails and toe boards.

Safe use of this equipment requires the selection of appropriate equipment that is of adequate strength and stability for the task, together with a sensible approach to work on the equipment. Under the new Work at Height Regulations the selection of platforms or podium steps should be considered in preference to stagings and steps as they provide a more stable work platform in many cases.

Ladders

Select a safe system of access. If both hands are needed to do the work then a ladder is not to be used. Ladders must be of sufficient strength to suit the work to be undertaken and be of the industrial and not domestic type.

More accidents arise each year from the use or misuse of ladders than from any other single piece of equipment.

- Ladders with broken stiles and rungs are very unsafe and should not be used under any circumstances.
- Ladders should be inspected and any damaged ladders reported to a supervisor.
- Ladders should never be sited on uneven ground.
- Ladders must be tied at both stiles (not the rungs) to a secure anchor point.
- Ladder should not be used where a safer method is available.
- There should be sufficient handhold at the top of the ladder or at the stepping off position.
- There must be sufficient foothold at each rung.
- Care should be taken when using a ladder near overhead electrical cables, crane contacts etc.
- Ladders must be at a suitable angle, 1 out to 4 up or 75°.
- The overlap of extension ladders must be at least three rungs.
- Ladders must be removed to storage, or made inaccessible by some means, at the end of each working day, to ensure that unauthorised access to scaffolds etc by others, particularly children, is prevented.

Stilts

Stilts used by operatives to gain access to high-level work areas such as ceiling fixing, are usually supplied in fixed or variable length versions made from durable lightweight material such as aluminium and nylon and designed to allow normal walking action. It is possible to become competent in the use of this equipment in a fairly short time, but it is essential that users do not try to exceed the design limitations by attempting excessively difficult tasks. To be used safely, the following conditions should be met:

- Proper training must be given to all users.
- Users should acquaint themselves with any manufacturer's limitations on the use of the equipment.
- The equipment must be properly maintained and regularly examined for faults.
- Stilts should only be used on reasonably level firm surfaces that are free from debris; never step over materials, cables or debris left on the floor surface or climb from one level to another.
- Ensure that the tools and materials needed to carry out the work at the elevated working levels do not present a hazard due to the risk of falling; one solution being the provision of a pouch to hold the tools and materials.
- Never use stilts near unguarded windows, stairwells or other potentially hazardous situations.

- If stilts are used adjacent to an open edge where a guardrail has been erected, the height of the rail is unlikely to be adequate and a further upper rail will be required. In this situation, the person responsible for erecting the guardrails should be informed when work on stilts is likely to take place, so that arrangements can be made for an upper rail to be erected that provides adequate protection.
- Exercise care when walking near or under obstacles at head height, and extreme caution when near electrified cables (aluminium is a conductor of electricity).
- Stilts should not be worn when travelling from one work area to another; they should be removed and refitted once at the new worksite.

Scaffolding

Around half of all deaths occur as a result of people falling from height - especially scaffolds.

- Scaffolds may only be erected, altered or dismantled under the direction of a person who carries a formal certificate of competence.
- Scaffold must be inspected regularly by a competent person and a record kept.
- Unsafe scaffold must be reported to the relevant person immediately.
- Platforms must be kept clear at all times.
- While scaffold is being erected or dismantled, 'Scaffold Incomplete' signs should be displayed.
- A securely tied ladder must always be used to climb up and down scaffold.
- All working platforms or edge protection must have a guard-rail and toe board and an intermediate guard-rail, a secured panel, or an extended toe board. These must not be removed. The most potentially dangerous occurrence in any scaffold is where guard rails are missing.
- Materials must be stacked adjacent to standards in small quantities, never between them. Heavy loading is only permitted in specially designed sections of the scaffold - loading bays.
- Materials must never be thrown, tipped or dropped from any height. A properly constructed chute or hoist must be used.
- Metal base plates must be used that are the correct size to provide safe bearing. The ground must be firm and level.
- Scaffold boards must always be in good condition. Damaged, rotten or notched boards must be replaced. Platform boards should not overlap and there must be no gaps between them.
- Standards must be upright and set out in accordance with the regulations. Internal and facade bracing is a statutory requirement.
- Scaffolding should be tied into the building or otherwise designed.

Mobile elevating work platforms

The Mobile Elevating Work Platform (MEWP) is the general name for a range of powered access platforms such as Scissor Lifts, Cherry Picker (Boom type), Mast Climber etc.

These machines are extremely versatile and can provide an effective and efficient means of working at height. Safe use requires planning and preparation as there are dangers associated with the use of this equipment including the risk of collapse, overturning, falling from the basket and being trapped against a structure

Avoiding these risks requires planning; a risk assessment should always be carried out to ensure that all obvious hazards have been considered:

- Other vehicle movement (plant, cars, buses).
- Ground conditions and quality (sloping, uneven or soft).
- Local overhead or underground hazards.
- Condition of the equipment.
- The work to be done, duration, materials, tools and weather conditions.

The work should then be planned to ensure that at least the following three control measures are in place:

- Safe Plant
- Safe Site
- Safe Operator

Safe Plant – Selection of the right equipment for the job, ensure that it is in good working order and has been thoroughly examined in the last six months. Weekly user checks should also be carried out. If on long term hire ensure that regular maintenance is also being done.

Safe Site – Make sure the work area is separated from other plant, vehicles and people. Make sure the boom cannot be caught by a passing truck. Check general and local ground conditions. Know what the weather forecast is if working outside. Make sure there is a rescue plan in place for either a fall or failure of the equipment.

Safe Operator – All operators of MEWPs must have been trained and be familiar with the machine they are using. Make sure operators are familiar with emergency procedures, fault reporting and inspection procedures.

When using boom type machines it is recommended that a fall-restraint safety harness is used. This should minimise the likelihood of the user falling out of the basket. If fall-arrest is used a fall rescue procedure will be needed.

For further information contact the manufacturer of the machine and refer to HSE publication MISC164 'Preventing Falls from boom-type mobile elevating work platforms'.

Further important reading: *AIS Health & Safety Handbook* and relevant AIS Fact File Information Sheets.

Completion

Provision of O & M (Operation and Maintenance) manual

If required under the terms of his engagement, the ceiling contractor will compile a manual detailing information relevant to the installation. This may include:

- Details of the manufacturer(s) of the ceiling grid, panels and other components.
- Description of the type(s) of ceiling(s), construction and finish. Manufacturer's instructions and source of replacement material.
- 'As built' drawings.
- Information on acoustic performance, surface spread of flame, contribution to structural fire protection (including test reports), resistance to corrosive atmosphere etc.
- Guidance on maintaining the integrity of structural fire protection and cavity barriers.
- Details of any special characteristics.
- Manufacturer's advice on cleaning, maintenance and repair.
- Advice on removal and replacement of tiles.

- Details of access panels and their use.
- Relevant COSHH data.

Maintenance

- With the exception of plasterboard ceilings, most suspended ceiling panels or tiles are factory finished and require no further decoration at the time of installation.
- Cleaning should be carried out in accordance with the manufacturer's recommendations.
- Soiled ceilings can be cleaned by chemical spray methods. Specialist cleaning companies should be consulted.
- In-situ redecoration of some suspended ceilings is possible. Before undertaking redecoration the effects on the acoustic and fire performance/characteristics should be considered.

Swimming Pools, Leisure Buildings, Aggressive Environments

Suspended ceilings that are to be installed above swimming pools, in leisure buildings and other interior environments may need to be able to cope with conditions of high humidity, condensation and corrosion. Particular care should be exercised in the selection of materials and fixing methods.

The AIS can provide information on the sources of appropriate specialised information.

Summary

In publishing this guide the AIS's aim is to help the project team achieve a completed building that looks and functions to its full design potential.

Whilst being only one of the many specialist trades involved, suspended ceilings have a disproportionate impact on the progress of the programme. The early appointment of a specialist suspended ceiling contractor who has the necessary experience and resources to achieve satisfactory completion is therefore of major importance.

Contractor membership of the Association of Interior Specialist will be a significant indicator of a contractor's suitability.

Appendix 1

List of references

- BS 476: *Fire tests on building materials and structures*
Part 4: 1970 (1984) *Non-combustibility test for materials*
Part 6: 1989 *Method of test for fire propagation for products*
Part 7: 1997 *Method for classification of the surface spread of flame of products*
Part 22: 1987 *Method for determination of the fire resistance of non-loadbearing elements of construction*

Part 23: 1987 *Methods for determination of the contribution of components to the fire resistance of a structure*

Part 31.1: 1983 *Methods for measuring smoke penetration through doorsets and shutter assemblies: Section 31.1: 1983 Method of measurement under ambient temperature conditions*

BS EN ISO 140: *Acoustics. Measurement of sound insulation in buildings and of building elements*
BS EN ISO 140-3: 1995 *Laboratory measurement of airborne sound insulation of building elements*
BS EN ISO 140-4: 1998 *Field measurements of airborne sound insulation between rooms*
BS EN ISO 717: *Acoustics: Rating of sound insulation in buildings and of building elements*
BS EN 717-1: 1997 *Airborne sound insulation*
BS EN 717-2: 1997 *Impact sound insulation*
BS EN 1364-1: 1999 *Fire resistance tests for non-loadbearing elements - walls*
BS EN 1364-2: 1999 *Fire resistance tests for non-loadbearing elements - ceilings*
BS EN 1365-4: 1999 *Fire resistance tests for loadbearing elements – columns*
BS EN 1366-1: 1999 *Fire resistance tests for service installations – ducts*
BS EN 1366-2: 1999 *Fire resistance tests for service installations – fire dampers*
BS EN 1991-1-1:2002 *Actions on structures. General actions. Densities, self-weight, imposed loads for buildings*

BS EN 12825: 2001 *Raised access floors*
BS EN 13964: 2004 *Suspended ceilings. Requirements and test methods*
BS 5234: *Partitions (including matching linings)*
Part 1: 1992 *Code of practice for design and installation*
Part 2: 1992 *Specification for performance requirements for strength and robustness, including methods of test*

BS 5492: 1990 *Code of practice for internal plastering*
BS 6180: 1999 *Code of practice for protective barriers in and about buildings*
BS 6206: 1981 (1994) *Specification for impact performance for flat safety glass and safety plastics for use in buildings*

BS 6262: 1982 *Code of practice for glazing for buildings*
Part 4: 1994 *Code of practice for safety related to human impact*
BS 8000: *Workmanship on building sites*
Part 5: 1990 *Code of practice for carpentry, joinery and general fixings*
Part 7: 1990 *Code of practice for glazing*
Part 8: 1994 *Code of practice for plasterboard partitions and drylinings*
Part 10: 1995 *Code of practice for plastering and rendering*
Part 11: *Code of practice for wall and floor tiling*
Part 11.1: 1989 (1995) *Ceramic tiles, terrazzo tiles and mosaics*

- Part 11.2: 1990 *Natural stone tiles*
Part 12: 1989 *Code of practice for decorative wallcoverings and painting*
BS 8212: 1995 *Code of practice for drylining and partitioning using gypsum plasterboard*
BS 8214: 1990 (1992) *Code of practice for fire door assemblies with non-metallic leaves*
BS 8300: 2001 *Design of buildings and their approaches to meet the needs of disabled people. Code of practice*

BS EN ISO 9000 (formerly BS 5750) *Quality systems*
The Building Regulations (England and Wales)
Approved Document B - *Fire Safety*
Approved Document E - *Resistance to the passage of sound*
Approved Document K - *Protection from falling, collision and impact*
Approved Document L2A - *Conservation of fuel and power. New buildings other than dwellings*
Approved Document L2B - *Conservation of fuel and power. Work in existing buildings that are not dwellings*
Approved Document M - *Access to and use of Buildings*
Approved Document N - *Glazing – Safety in relation to impact, opening and cleaning*
Regulation 7 - *Materials and workmanship*
The Building Standards (Scotland) Regulations
The Building Regulations (Northern Ireland)
The Health & Safety at Work Act
Management of Health & Safety at Work Regulations
Control of Substances Hazardous to Health Regulations (COSHH)
The Construction (Design and Management) Regulations (CDM)
Health & Safety Commission (HSC) Approved code of practice on Management of health and safety at work
Glass and Glazing Federation (GGF) Codes of practice on Glass handling, storage, transport, and safety in the flat glass industry
Property Services Agency (PSA) Method of Building Performance Specification - *MOB PF2 FS/SP: Platform Floors (Raised Access Floors)*

Association of Interior Specialists references

- AIS Profile*
AIS Fact File of Information Sheets
AIS Health & Safety Handbook
AIS Site Guide for Drylining
AIS Site Guide for Partitioning
AIS Site Guide for Raised Access Flooring
AIS Site Guide for Suspended Ceilings
AIS Site Guide for Wallcoverings
AIS Website: www.ais-interiors.org.uk

Note: Information contained within this site guide is current at the time of going to press.

The information and guidance contained in this site guide are provided in good faith in the interests of improving safety and good practice.

Whilst every care has been taken in its preparation, the Association of Interior Specialists cannot accept any responsibility for injuries to persons or damage to property, or for any violations of laws or regulations which may arise from the use of or reliance upon the information and guidance contained herein.

The information is for general guidance on good practice only. Each case must be treated with due regard to the location and circumstances prevailing.

Published by Association of Interior Specialists
Copyright © Association of Interior Specialists

AIS gratefully acknowledges the considerable help given by all those AIS members involved in the preparation of this site guide.



Site guide

Suspended ceilings

Association of Interior Specialists

Olton Bridge
245 Warwick Road
Solihull
B92 7AH

Tel: 0121 707 0077
Fax: 0121 706 1949
Email: info@ais-interiors.org.uk

Serving the interiors sector www.ais-interiors.org.uk